



Optima – HD

Chilled Water Precision Air Conditioner For Critical Application
Cooling Capacity: 42.1kW~180.9kW



The OPTIMA product family from AIRSYS is designed specifically for medium to large data center installations. OPTIMA units combine precise temperature and humidity control with outstanding reliability and energy efficiency, throughout 24*7 operation.

The OPTIMA-HD range is a high cooling density product, utilizing chilled water for heat rejection from either a central chiller plant or free cooling water. These units do not require compressors or outdoor condensers, which can reduce capital investment and ongoing maintenance costs, while providing greater energy efficiency and reliability.

OPTIMA-HD has two versions:

OPTIMA-HD.CW: Single chilled water circuit

OPTIMA-HD.CWD: Double chilled water circuits

Unit Identification

09 Code for Custom Design
3 alphabetic and numerical code

01 Product Type

OPTIMA-HD: OPTIMA-HD is a product with high cooling density, can be abbreviated as "OPTHD".

07 Cabinet Size Code

OPTIMA-HD.CW: B1~B4
OPTIMA-HD.CWD: D1~D3

03 Air Supply Scheme

OVER – Up flow, abbr. as "O" (Only available for OPTIMA-HD.CW)
UNDER – Down flow, abbr. as "U"

05 Heat Rejection

CW-Chilled water cooling single circuit.
CWD-Chilled water cooling double circuits.

01	02	03	04	05	06	07	08	09
OPTIMA-HD	.	O U	.	CW CWD	40 60 ...	B1...B4 D1...D3	.	XXX

02 Separator Character "."

04 Separator Character "."

06

Nominal Cooling Capacity: kW

08 Separator Character "."

Cooling Schemes

Single coil chilled water system(CW)

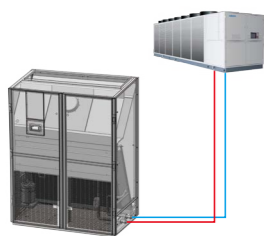

The single coil chilled water system (CW) transfers heat from the indoor air directly to a chilled water circuit. The user can connect to a new or existing chilled water source.

Indoor unit: OPTIMA.CW

Outdoor unit: user supplied chilled water source

Double coil chilled water system(CWD)

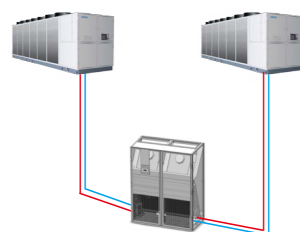

Double coil chilled water systems (CWD) each contain two independent chilled water circuits and connect to independent cooling sources. The two circuits are utilized for redundancy.

Indoor unit: OPTIMA.CWD

Outdoor unit: user supplied chilled water source

Operating Range & Control Accuracy

Operating Range

Water pressure: Greater than the overall system pressure drop, but lower than 1,250KPa.

Control Accuracy

Temperature Range and Accuracy:

Range: 15~35°C, Accuracy: ±1°C;

Humidity Range and Accuracy:

Range: 35~80%, Accuracy: ±5%

Application

Medium to large telecommunication exchange rooms

Medium to large data centers and computer rooms

Museums and libraries

Precision machining equipment centers

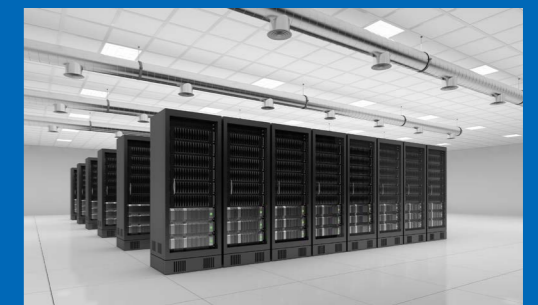
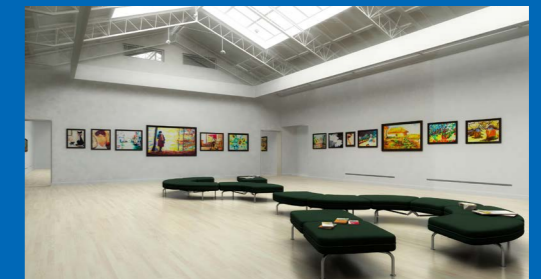

High Lights

Compact, High Cooling Density, High Air Volume

The OPTIMA-HD range has been designed to be contained within a compact enclosure, to simultaneously achieve a high cooling density and high air volume; it saves precious space within critical areas. The maximum cooling density = 80kW/m² (two circuits operating at the same time).

Precise Control

The control accuracy for temperature is $\pm 1^{\circ}\text{C}$ and for Relative humidity is $\pm 5\%$.

High Efficiency

OPTIMA-HD units are equipped with energy efficient EC supply fans and, by increasing the return water temperature, the EER of the chiller can be optimized. Free cooling options are also available which are able to further reduce the energy consumption of the air conditioning system.

Various Supply Air Arrangements

CW: up flow with duct, front-discharge under flow, under flow with the underfloor fan section.

CWD: front-discharge under flow, under flow with the underfloor fan section.



EC Fans

Highly efficient EC fans are supplied with OPTIMA products.

Electric Heater

The construction of the electric heater element (stainless steel pipe with wrapped fins) allows for a reduced operating temperature, therefore eliminating ionization, and avoiding unpleasant odors.

Self-diagnosis

All the microprocessor-connected components are continuously monitored and controlled and, in case of malfunction, the unit is shut down and the fault is shown on the display.

Isolated Control Panel

All the electrical and control components are installed in an isolated control panel with orderly wiring and clear labeling, meeting the IEC standards.

Easy maintenance

The technical compartment housing the compressor, humidifier, control and safety devices is separates from the air flow, enabling ordinary service and preventive maintenance to occur during operation.

Data center power consumption is generally divided between four major sources; IT equipment, cooling systems, backup power and lighting systems. The specific proportions are different in each data centers, however a typical split is presented here.

As the pie chart show, the energy consumption of the cooling system is second only to the actual IT equipment; i.e. the air conditioning systems account for a large portion of the total energy consumption of the data center. Therefore, by taking advantage of free cooling solutions (and hence reducing the run hours of the compressors) large energy savings are potentially achievable. AIRSYS has developed both direct and indirect free cooling systems, as well as dual heat-rejection mode units which can significantly reduce the overall energy consumption of a data center. Options are available or configurable to suit any and all installation requirements.

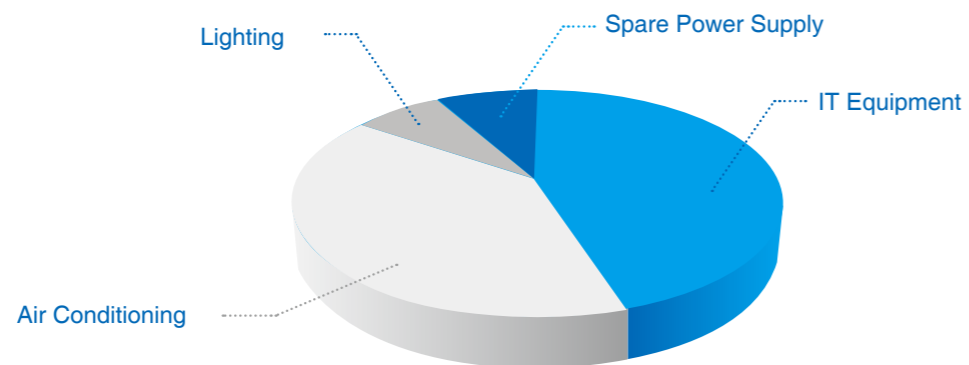

Data Center Energy Consumption



Energy Saving Technologies

Optional Energy Saving Running Modes

The OPTIMA family of products offers two running modes which may be chosen from the controller display:

Standard running mode:

In this mode, the temperature and humidity are controlled within narrower ranges;

Energy saving mode:

In this mode, good energy savings can be achieved through allowing the temperature and humidity to be controlled within wider ranges.

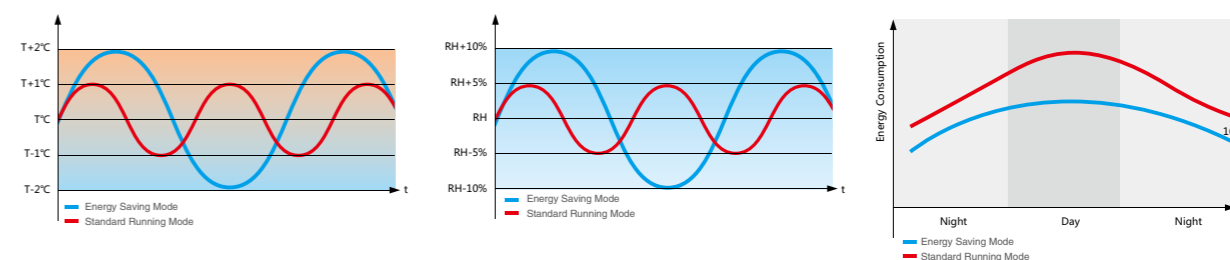

Supply Air Temperature and Pressure Control (option)

Supply air temperature control, as the name suggests, means driving the operation of the compressor based on the air temperature at the supply air discharge location; when cool air is being supplied at the setpoint temperature, the compressor is stopped until supply air temperature begins to increase. This control method provides accurate adjustment of the cooling capacity according to actual demand and can save a considerable amount of energy.

Supply air temperature control is typically applied to cold aisle cooling systems. As the cold aisle temperature profile is uniform (i.e. there is no short-circuiting of air), accurate reading of the supply air temperature is simple to obtain from the unit supply air discharge location.

Because the supply air and cold aisle air temperatures are equal, the cold air is supplied directly to the equipment requiring cooling and no energy is wasted cooling the rest of the room. Compared to return air temperature control systems, supply air control systems can operate at a higher supply air temperature under the same cooling demand conditions. As well as this, evaporating temperatures will typically be higher and therefore more energy efficient.

For down flow units utilizing supply air temperature control, the differential air pressure can be monitored to ensure the cool air has been evenly distributed to all the servers.

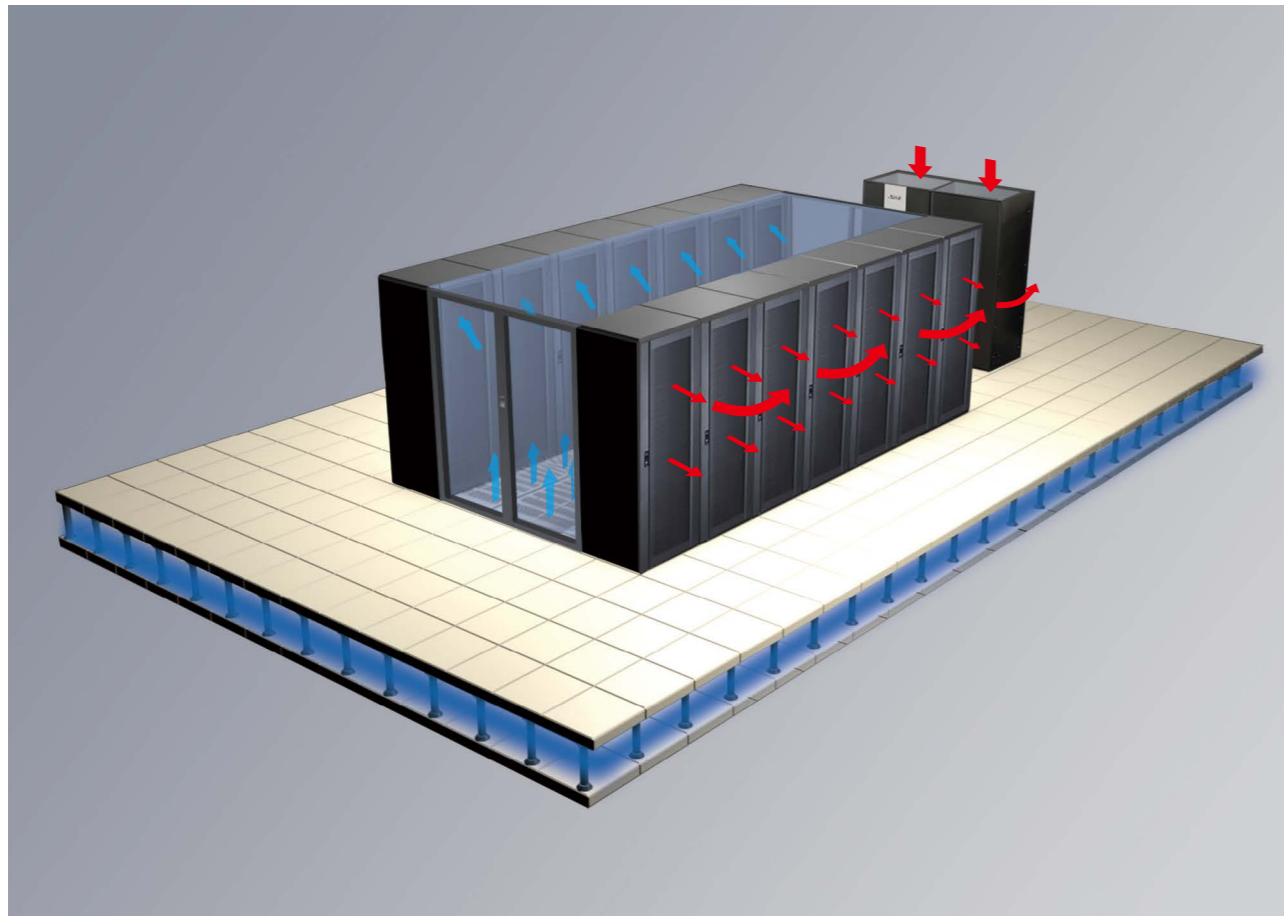

EC Fan

An EC fan refers to a centrifugal fan that utilizes an Electronically Commutated motor (or brushless DC motor). EC fans have numerous benefits including:

Energy Efficiency

EC fans have brushless DC motors and integrated control modules. Motor efficiencies of 85-90% are achievable; 30% to 50% higher than traditional AC fans.

The difference in energy efficiency between variable speed EC fan control and traditional on/off fixed speed AC fans can be seen in the graph; the bars show the power consumption of fans which are switched in gradually as required while the blue curve shows the power consumption with infinitely variable speed control.

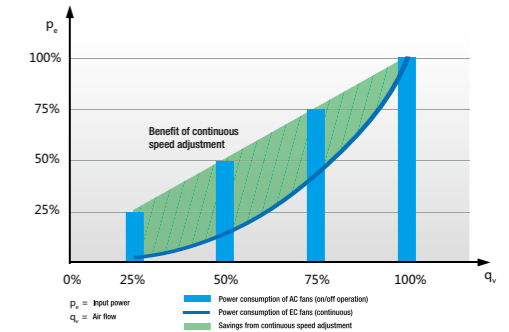

Lower Noise

In a given installation, switching off half the fans (and halving the air flow) will typically only reduce the generated noise by approximately 3 dB. Compare this to EC fans, where reducing fan speed to provide half the air flow typically yields an reduction of approximately 15 dB. This is possible as EC fans are able to operate across an infinitely controllable speed range, which in turn effectively avoids electromagnetic and rectifier noise (generated by other traditional motor and speed control devices), thus reducing the overall noise level.

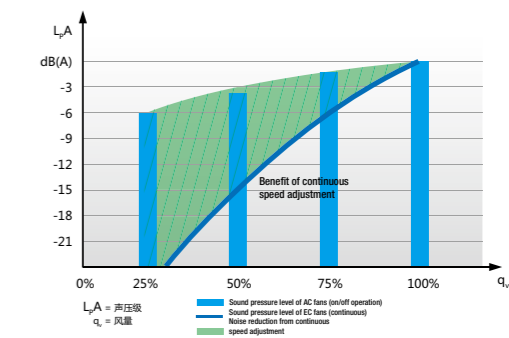

In the graph, the bars indicate the sound pressure level of fans which are switched in gradually as required and the blue curve shows the sound pressure level with infinitely variable speed control.

As can be seen from the picture EC fan sound pressure level is 12dB lower compared to the traditional AC fan.

Compact, Integrated Electronic Control System

All EC fans have dedicated speed control modules and filters built into the motor assembly, making for a compact and self-contained solution. All that is required is to connect the main power supply and the sensor signals to the controller for complete speed control of between 10% and 100%. EC fans provide a simple, convenient solution and can also support group control and remote monitoring.

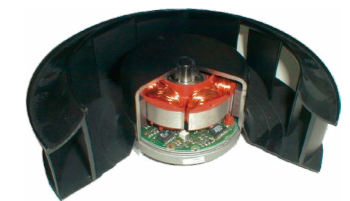

Wide Working Voltage

Wide AC input voltage range: 1~200-277VAC or 3~380-480VAC 50&60Hz

Wide DC input voltage range: 16-28VDC or 36-57VDC

Cooling Without Compressors

OPTIMA-HD.CW units use only chilled water for heat rejection, therefore have no mechanical (DX) cooling components. Chilled water enters into the cooling coil and exchanges heat directly with the return air to lower the room temperature. Such a system is typically more energy efficient and reliable than a DX cooling system.

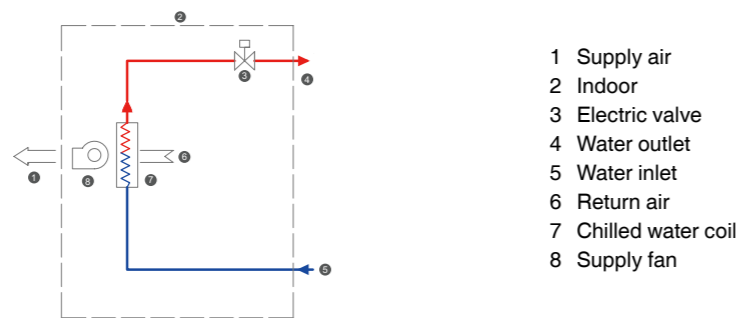

OPTIMA-HD.CWD operational modes:

1. Energy-Saving Mode: Circuit I uses chilled water from a central chiller plant, while circuit II uses chilled water from free cooling water sources. The system will decide which circuit is to be used to maximize efficiency, according to the ambient conditions.

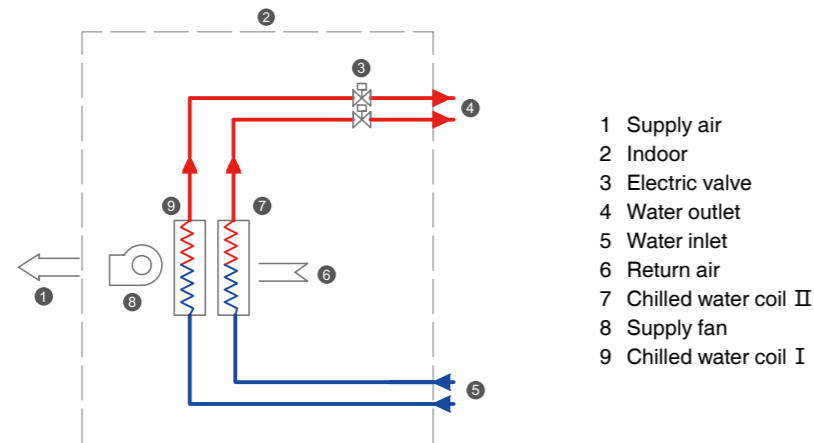

For example, in summer, only circuit I will be used and in winter, only circuit II will be used. As ambient conditions permit throughout the remainder of the year, by regulating 2 electronic two-way valves, circuit II is used as the priority cooling and circuit I is used as supplementary cooling.

Such an arrangement is more energy efficient due to the maximization of free cooling.

2. Reliability Mode: both circuits use chilled water from a central chiller plant; one operational, one standby. When one circuit cannot supply sufficient capacity to meet the cooling demand, the second circuit will also operate to provide supplementary cooling.

Unit Configuration

OPTIMA-HD Product Standard Configuration

Standard Configuration	OPTIMA-HD.CW	OPTIMA-HD.CWD
Powder painted steel frame	●	●
Powder painted steel panel with inside thermal and acoustic insulation	●	●
Backward curve, single inlet, centrifugal fan with 3 phase EC powered Electronic Commuted motor	●	●
One V type copper tube aluminum fin coil	●	—
Two copper tube aluminum fin coils	—	●
Condensing water tray	●	●
Proportional controlled electrode type humidifier, various capacity available	●	●
Stainless steel electric heater, various capacity available	●	●
G4 class air filter	●	●
Motorized 2-way valve	●	●
Temperature and RH sensor at return air inlet	●	●
Air pressure switch for supply fan protection	●	●
Return air plenum for up flow unit(mandatory for up flow unit)	●	—
Supply air plenum for down flow unit(mandatory for down flow unit)	●	●
Microprocessor control	●	●
Electrical control panel	●	●
Wooden packaging	●	●

Note: "●"standard configuration, "—" no option available.

Options for OPTIMA-HD Product

Option	OPTIMA-HD.CW	OPTIMA-HD.CWD
AC centrifugal fan	○	○
Motorized 3-way valve	○	○
Air pressure switch for clogged filter alarm	○	○
Supply air plenum for up flow unit	○	—
Supply air temperature sensor	○	○
Supply air pressure sensor	○	○
Installation support stand with adjustable legs	○	○
Floor water leakage alarm kit	○	○
Additional floor water detector	○	○
Colored touch screen graphical user interface	○	○
Remote display controller	○	○
RS232 communication card	○	○
RS485 communication card	○	○
PcoWeb card serve as web based server	○	○
Clock card	○	○
Communication protocol converter	○	○
GSM short message module	○	○
Phase sequence protection relay for power supply	○	○
Carton packaging	○	○

Note: "○"option available, "—" no option available.

Electric Heater/Humidifier Selection Sheet

		B1	B2	B3	B4	D1	D2	D3
Heat capacity (kW)	9	●	—	—	—	●	—	—
	13.5	○	●	—	—	○	●	—
	18	—	○	●	●	—	○	●
	27	—	—	○	○	—	—	○
Humidification capacity (kg/h)	8	●	●	●	●	●	●	●
	10	○	○	○	○	○	○	○
	13	○	○	○	○	○	○	○
	15	○	○	○	○	○	○	○

Note: "●" means standard configuration, "○" means option, "—" means N/A.

Group Control

Continuous and reliable operation of the air conditioning systems is critical for the successful operation of data center equipment. As a result of the high proportion of power consumed by such air conditioning systems, energy consumption has been a challenge faced by modern data centers. AIRSYS precision air conditioners aim to address this challenge, in part, through effective group control and rotation functions. Such control

philosophies ensure consistent room temperature and humidity, together with continuous reliable operation (generally, by the addition of a spare unit for redundancy) whilst minimizing the total power required for the air conditioning. Group control and rotation functions will also typically extend unit life and effectively save energy by improving the overall management of the system.

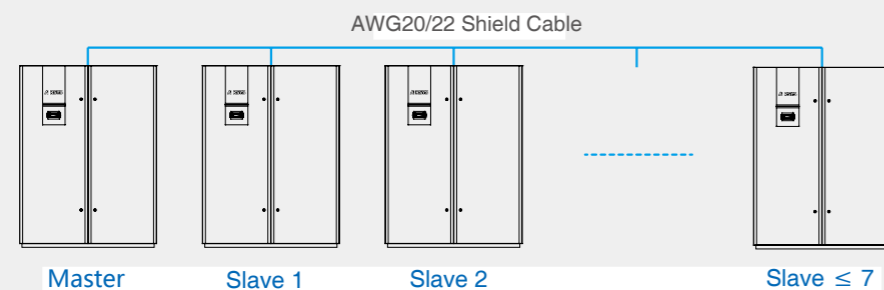

Remote Control & Network Monitoring

Networking and Monitoring of air conditioning equipment is typically a subsystem of a Building Management System (BMS) and provides centralized monitoring and management of all the air-conditioning equipment.

Thanks to years of experience in the production and application of precision air conditioning equipment, AIRSYS is able to provide a variety of monitoring systems ranging from simple SMS alarm monitoring to

the most sophisticated tERA cloud based GPRS wireless centralized monitoring system. There is a solution available to suit all sites and installations.

A given unit can be remote controlled or monitored via several means:

- 3 kinds of local direct cable connection
- 3 kinds of LAN network connection
- 4 kinds of wireless network connection

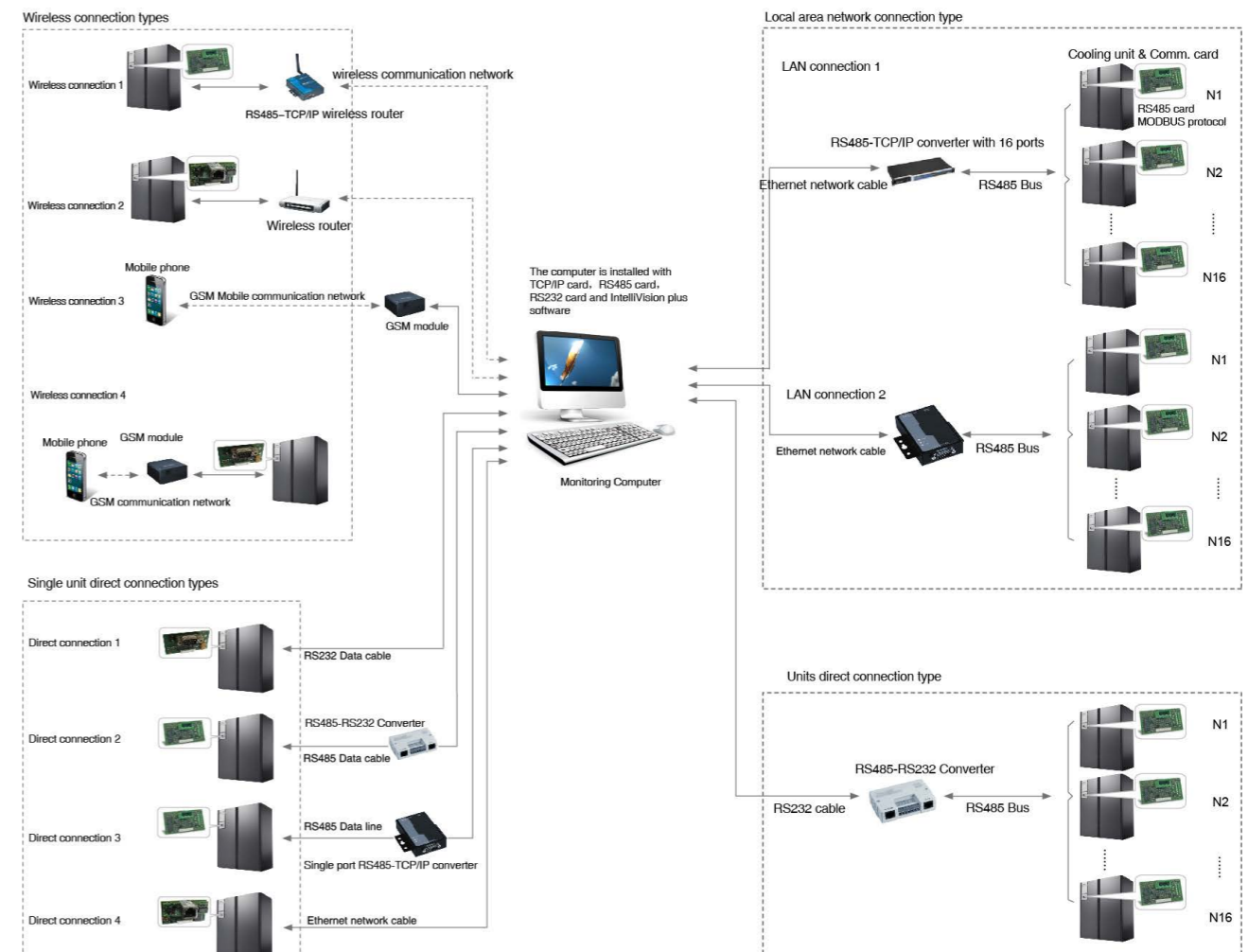

OPTIMA-HD.CW

Unit Model		40B1	60B1	80B2	100B2	120B3	140B3	160B4	180B4
Supply air scheme		O/U							
Cooling capacity									
Total cooling capacity(2)	kW	24.8	30.3	40.8	47.7	55.8	66.5	80.5	100.2
Sensible cooling capacity(2)	kW	22.1	26.2	36.8	41.5	48.8	57.7	72.7	86.7
Total cooling capacity(3)	kW	19.3	23.8	31.5	37.4	43.5	50.0	62.7	76.1
Sensible cooling capacity(3)	kW	18.3	21.3	29.5	34.0	41.2	47.0	59.0	69.4
Cooling coil									
Waterflow(2)	m ³ /h	7.2	9.6	14.2	17.3	19.5	24.7	26.3	28.4
Water pressure drop(coil+valve)(2)	kPa	95.0	97.0	86.0	94.0	93.6	91.2	98.6	83.9
Waterflow(3)	m ³ /h	5.9	8.1	12.9	14.6	17.4	20.3	22.8	26.3
Water pressure drop(coil+valve)(3)	kPa	71.2	75.0	73.0	65.5	89.6	82.7	83.9	62.4
Supply fan									
Type		Caseless backward EC centrifugal fan							
Qty.	n.	1	1	2	2	3	3	3	3
Air volume	m ³ /h	11700	12600	22600	23600	31800	32600	37200	37200
External static pressure (ESP)(4)	Pa	Standard ESP is 75Pa, adjustment range is 50-300Pa							
Power input	kW	1.9	2.3	2×2.6	2×2.8	3×1.9	3×2.1	3×2.4	3×2.6
Current input	A	2.8	3.5	2×3.8	2×4.4	3×2.8	3×3.3	3×3.6	3×4.0
Power input(5)	kW	3.5	3.5	2×3.5	2×3.5	3×3.5	3×3.5	3×3.5	3×3.5
Current input(5)	A	6.4	6.4	2×6.4	2×6.4	3×6.4	3×6.4	3×6.4	3×6.4
Noise level(6)	dB	66	69	69	69	69	69	69	69
Electric heater(7)									
Type		Stainless steel							
Heating capacity	kW	9	9	13.5	13.5	18	18	18	18
Current input	A	13.3	13.3	20.3	20.3	27.3	27.3	27.3	27.3
Working steps	n.	2	2	2	2	2	2	2	2
Humidifier(7)									
Type		Electrode							
Humidification capacity	kg/h	8	8	8	8	8	8	8	8
Power input	kW	6.0	6.0	6.0	6.0	6.0	6.0	6.0	6.0
Current input	A	9.2	9.2	9.2	9.2	9.2	9.2	9.2	9.2
Unit power supply									
Power source		380V/3Ph/50Hz							
Unit max. operating power input(8)	kW	16.9	17.3	24.7	25.1	29.7	30.3	31.2	31.8
Unit max. operating current(8)	A	25.3	26.0	37.1	38.3	44.9	46.4	47.3	48.5
Unit piping connection									
Condensing water drainage Φ	in	3/4"	3/4"	3/4"	3/4"	3/4"	3/4"	3/4"	3/4"
Humidifier water supply Φ	in	1/2"	1/2"	1/2"	1/2"	1/2"	1/2"	1/2"	1/2"
Chilled water inlet/outlet	in	1 1/2"	1 1/2"	2"	2"	2"	2"	2 1/2"	2 1/2"
Unit external dimensions and Weight									
Width	mm	900	900	1750	1750	2490	2490	2905	2905
Depth	mm	900	900	900	900	900	900	900	900
Height (O/U) (9)	mm	1960/1730	1960/1730	1960/1730	1960/1730	1960/1730	1960/1730	1960/1730	1960/1730
Return air plenum height(10)	mm	400	400	400	400	400	400	400	400
Supply air plenum height(11)	mm	550	550	550	550	550	550	550	550
Weight	kg	375	405	525	560	670	750	840	910
Wooden packaging dimensions and Weight									
Width	mm	1102	1102	1952	1952	2692	2692	3107	3107
Depth	mm	1027	1027	1027	1027	1027	1027	1027	1027
Height (O/U)	mm	2166	2166	2166	2166	2166	2166	2166	2166
Return air plenum height	mm	576	576	576	576	576	576	576	576
Supply air plenum height	mm	1906	1906	1906	1906	1906	1906	1906	1906
Weight	kg	460	490	650	685	825	905	1020	1090

- (1) O : Up flow U : Down flow;
- (2) Return air dry bulb temperature 24°C , RH50% , inlet/outlet chilled water temperature: 7°C/12°C;
- (3) Return air dry bulb temperature 28°C , RH40% , inlet/outlet chilled water temperature: 10°C/15°C;
- (4) For ESP over 300 Pa, Contact manufacturer;
- (5) Option , AC fan;
- (6) Tested at 1m distance, free field;
- (7) The default capacity, please refer to "electric heater/ humidifier selection sheet" for other capacity;
- (8) Max. operating power input/current: as above spec sheet, unit under the condition of dehumidification plus 100% electric reheat;
- (9) Excluding the height of return air plenum of up flow unit and supply air plenum of down flow unit;
- (10) Up flow unit is required and to be installed at the bottom, the total height is up to 2340mm. Please select OPTIMA.CW series if the maximum product total height is less than 2000mm;
- (11) Down flow unit is required and may sink under-neath floor to supply air or be installed on the floor to supplier air along the surface of the floor.

OPTIMA-HD.CWD

Unit Model		50D1	60D1	80D2	100D2	120D3	140D3
Supply air scheme(1)		U					
Cooling capacity							
Total cooling capacity(2)	kW	50.4	61.1	81.0	100.7	120.5	143.2
Sensible cooling capacity(2)	kW	44.8	55.0	73.7	90.6	109.7	131.7
Total cooling capacity(3)	kW	40.0	49.3	59.6	75.4	95.8	112.8
Sensible cooling capacity(3)	kW	35.6	43.4	53.6	67.8	87.2	104.9
Cooling coil							
Waterflow(2)	m ³ /h	7.7	9.6	12.7	14.8	17.9	22.0
Water pressure drop(coil+valve)(2)	kPa	101.1	123.1	83.1	83.2	184.6	156.6
Waterflow(3)	m ³ /h	6.1	7.9	9.8	11.8	15.0	18.5
Water pressure drop(coil+valve)(3)	kPa	87.7	92.1	56.7	50.8	127.8	113.8
Supply fan							
Type		Caseless backward EC centrifugal fan					
Qty.	n.	1	1	2	2	3	3
Air volume	m ³ /h	11600	12300	23600	22800	31200	33600
External static pressure (ESP)(4)	Pa	Standard ESP is 75Pa, adjustment range is 50-300Pa					
Power input	kW	2.6	2.9	2×2.5	2×2.9	3×2.3	3×2.8
Current input	A	3.3	4.7	2×3.9	2×4.7	3×3.2	3×4.5
Power input(5)	kW	3.5	3.5	2×3.5	2×3.5	3×3.5	3×3.5
Current input(5)	A	6.4	6.4	2×6.4	2×6.4	3×6.4	3×6.4
Noise level(6)	dB	69	69	69	69	69	69
Electric heater(7)							
Type		Stainless steel					
Heating capacity	kW	9	9	13.5	13.5	13.5	13.5
Current input	A	13.3	13.3	20.4	20.4	20.4	20.4
Working steps	n.	2	2	2	2	2	2
Humidifier(7)							
Type		Electrode					
Humidification capacity	kg/h	8	8	8	8	8	8
Power input	kW	6.0	6.0	6.0	6.0	6.0	6.0
Current input	A	9.2	9.2	9.2	9.2	9.2	9.2
Unit power supply							
Power source		380V/3Ph/50Hz					
Unit max. operating power input(8)	kW	17.4	17.9	24.5	25.3	26.4	27.9
Unit max. operating current(8)	A	25.8	27.2	37.4	39.0	39.2	43.1
Unit piping connection							
Condensing water drainage Φ	in	3/4"	3/4"	3/4"	3/4"	3/4"	3/4"
Humidifier water supply Φ	in	1/2"	1/2"	1/2"	1/2"	1/2"	1/2"
Chilled water inlet/outlet	in	1 1/2"	1 1/2"	2"	2"	2 1/2"	2 1/2"
Unit external dimensions and Weight							
Width	mm	1250	1250	1750	1750	2560	2560
Depth	mm	900	900	900	900	900	900
Height (O/U) (9)	mm	1900	1900	1900	1900	1900	1900
Supply air plenum height(10)	mm	550	550	550	550	550	550
Weight	kg	380	405	465	490	580	640
Wooden packaging dimensions and Weight							
Width	mm	1452	1452	1952	1952	2762	2762
Depth	mm	1027	1027	1027	1027	1027	1027
Height (O/U)	mm	2106	2106	2106	2106	2136	2136
Supply air plenum height	mm	1906	1906	1906	1906	1906	1906
Weight	kg	485	510	590	615	740	800

- (1) U:Down flow;
- (2) Single cooling coil offers. Under the standard condition, the total cooling capacity will increase by 45% when two coils work together;
- (3) Return air dry bulb temperature 24°C, RH50%,inlet/outlet chilled water temperature: 7°C/12°C;
- (4) Return air dry bulb temperature 28°C,RH40%,inlet/outlet chilled water temperature: 10°C/15°C;
- (5) Option , AC fan;
- (6) Tested at 1m distance, free field;
- (7) The default capacity, please refer to "electric heater/ humidifier selection sheet" for other capacity;
- (8) Max. operating power input/current: as above spec sheet, unit under the condition of dehumidification plus 100% electric reheat;
- (9) Down flow unit is required and may sink underneath floor to supply air or be installed on the floor to supplier air along the surface of the floor. Please select OPTIMA.CWD series if required up flow unit.

Unit Dimension Drawing

B1 Unit Cabinet Dimension Drawing for Up Flow Unit

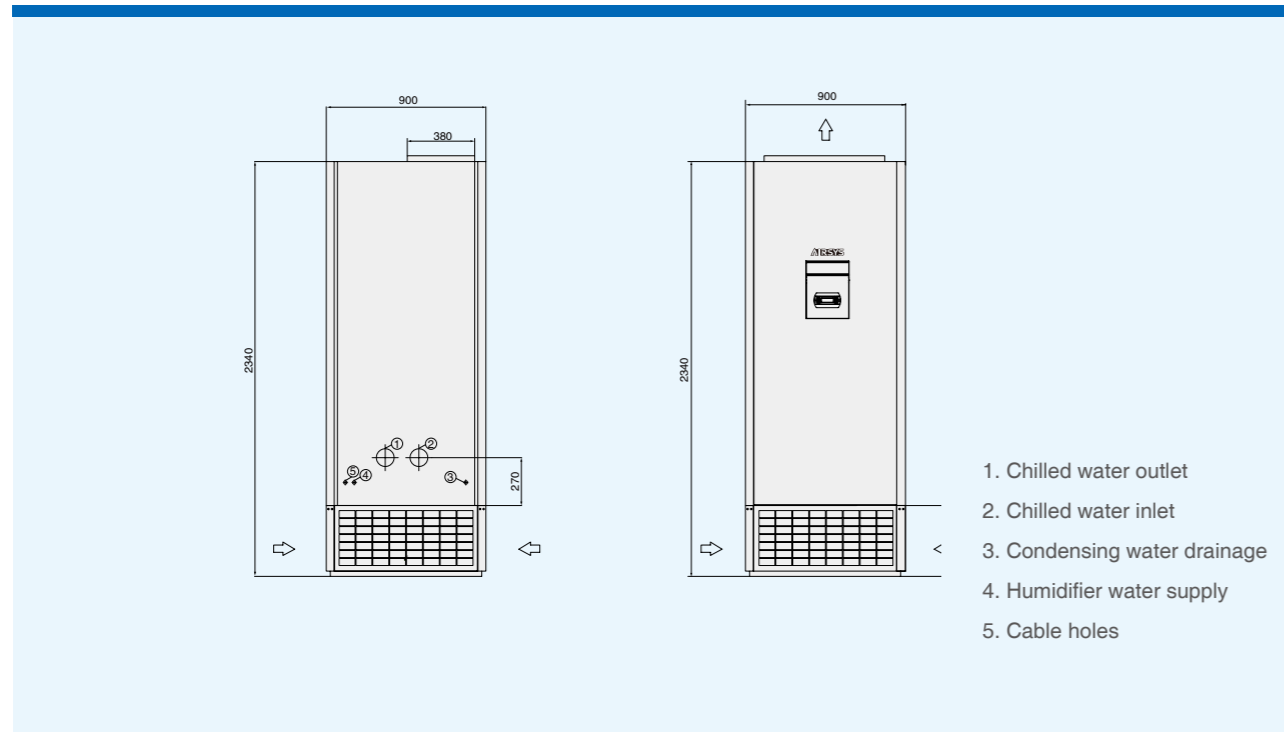

B2 Unit Cabinet Dimension Drawing for Up Flow Unit

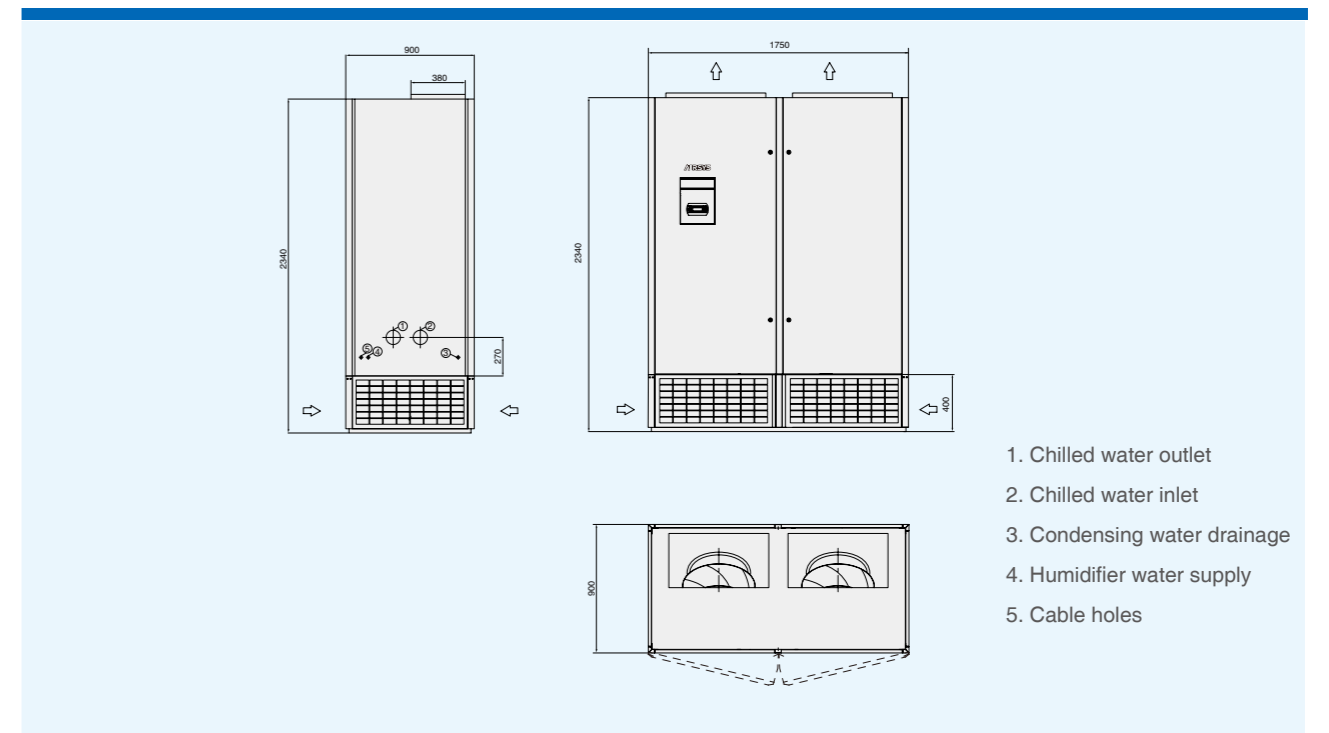

B1 Unit Cabinet Dimension Drawing for Under Flow Unit

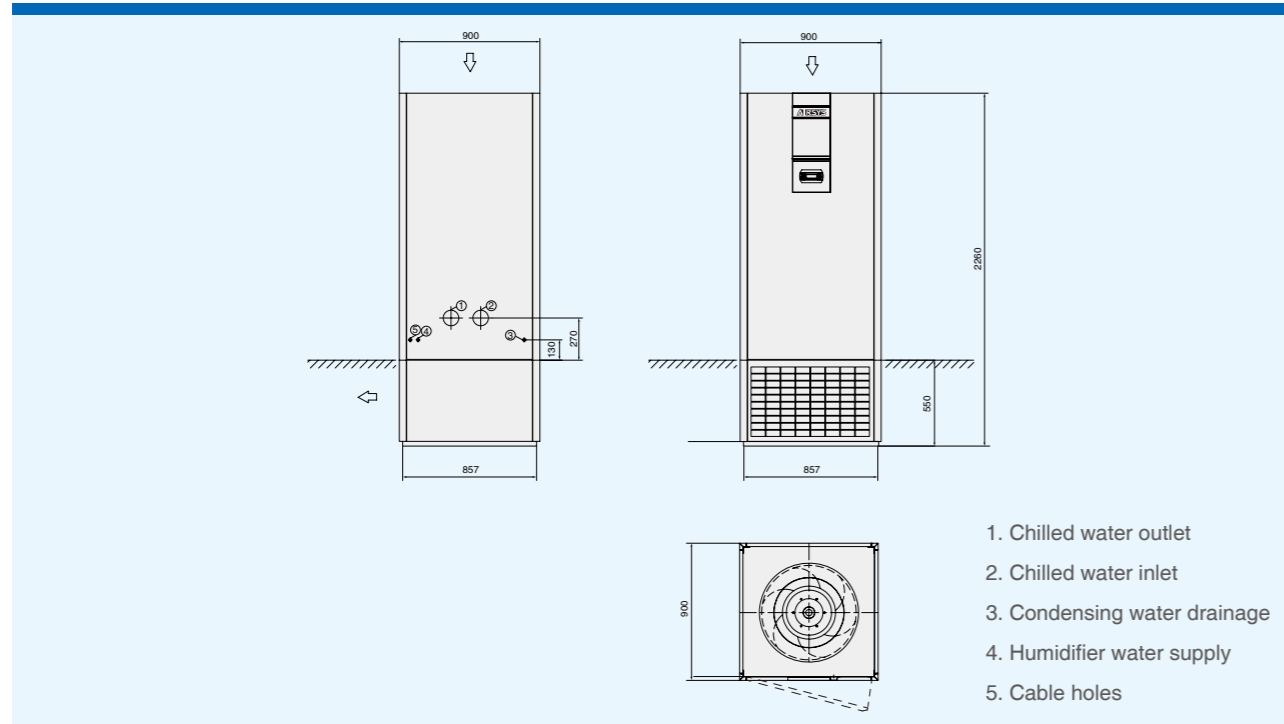

B2 Unit Cabinet Dimension Drawing for Under Flow Unit

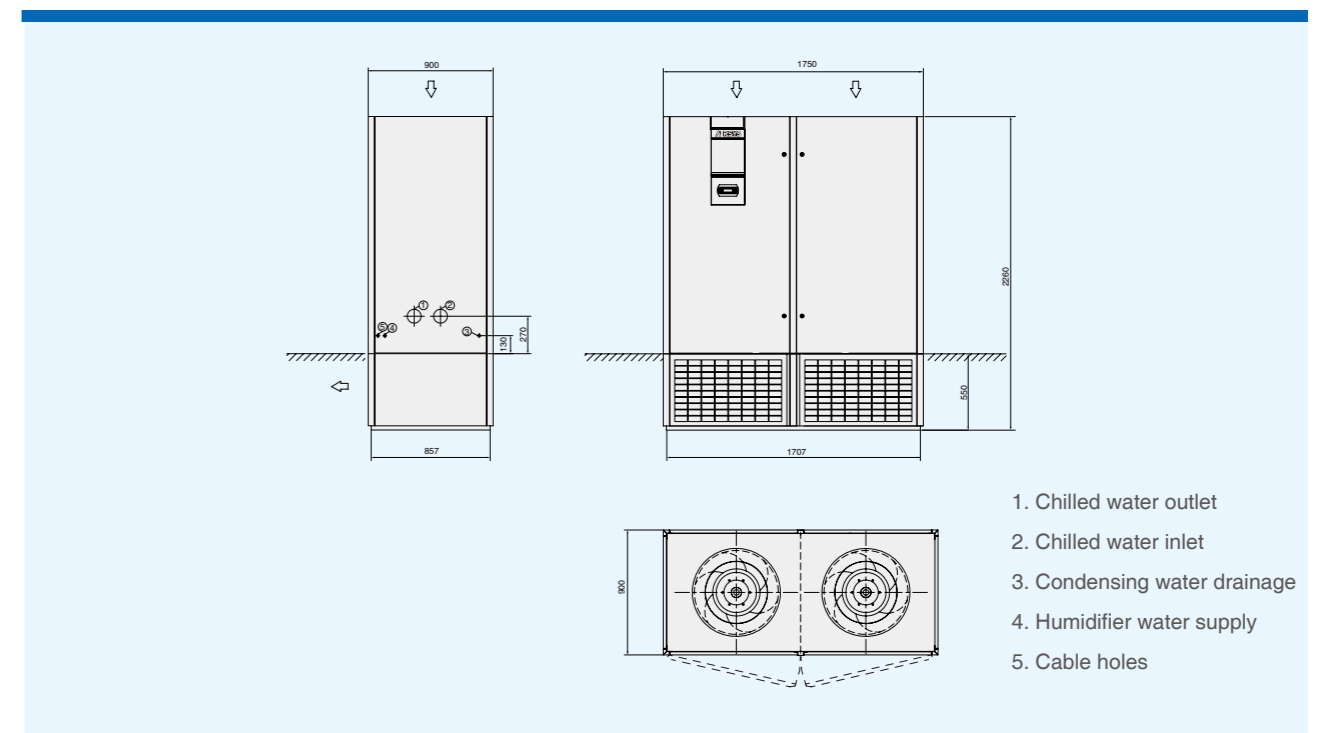

B3 Unit Cabinet Dimension Drawing for Up Flow Unit

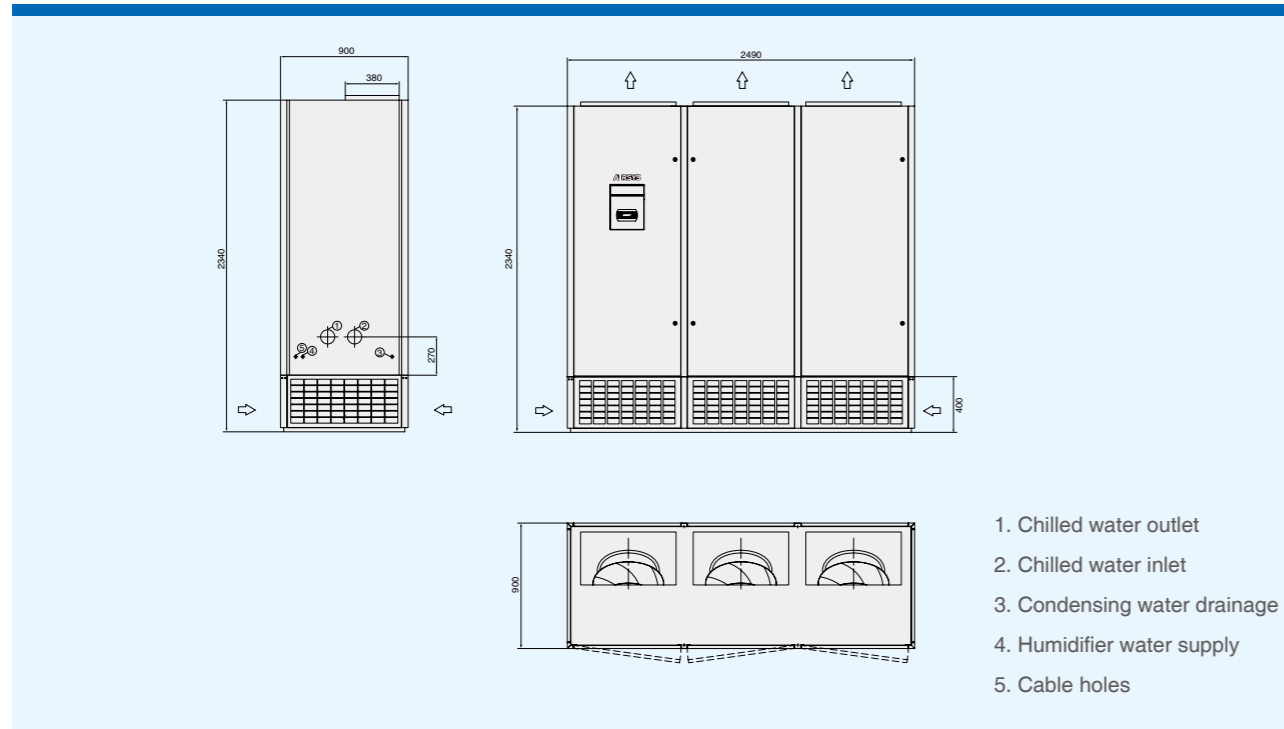

B4 Unit Cabinet Dimension Drawing for Up Flow Unit

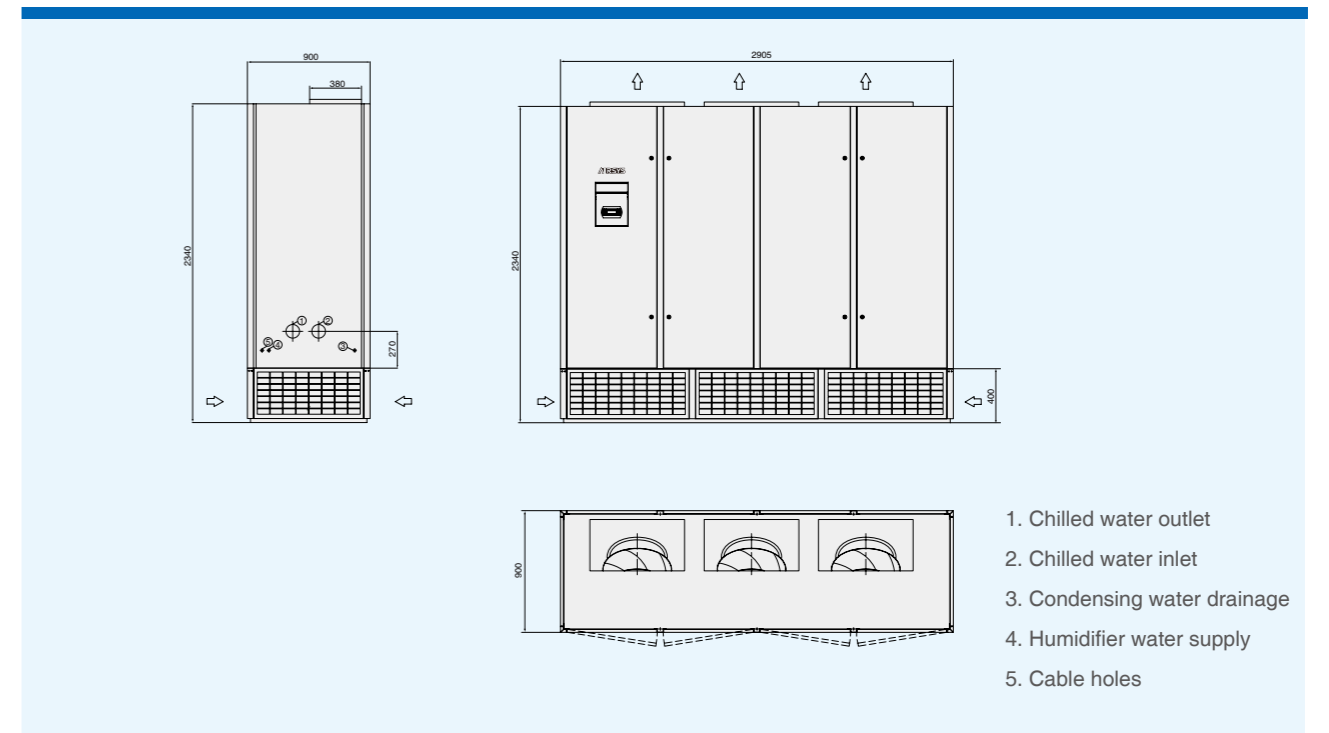

B3 Unit Cabinet Dimension Drawing for Under Flow Unit

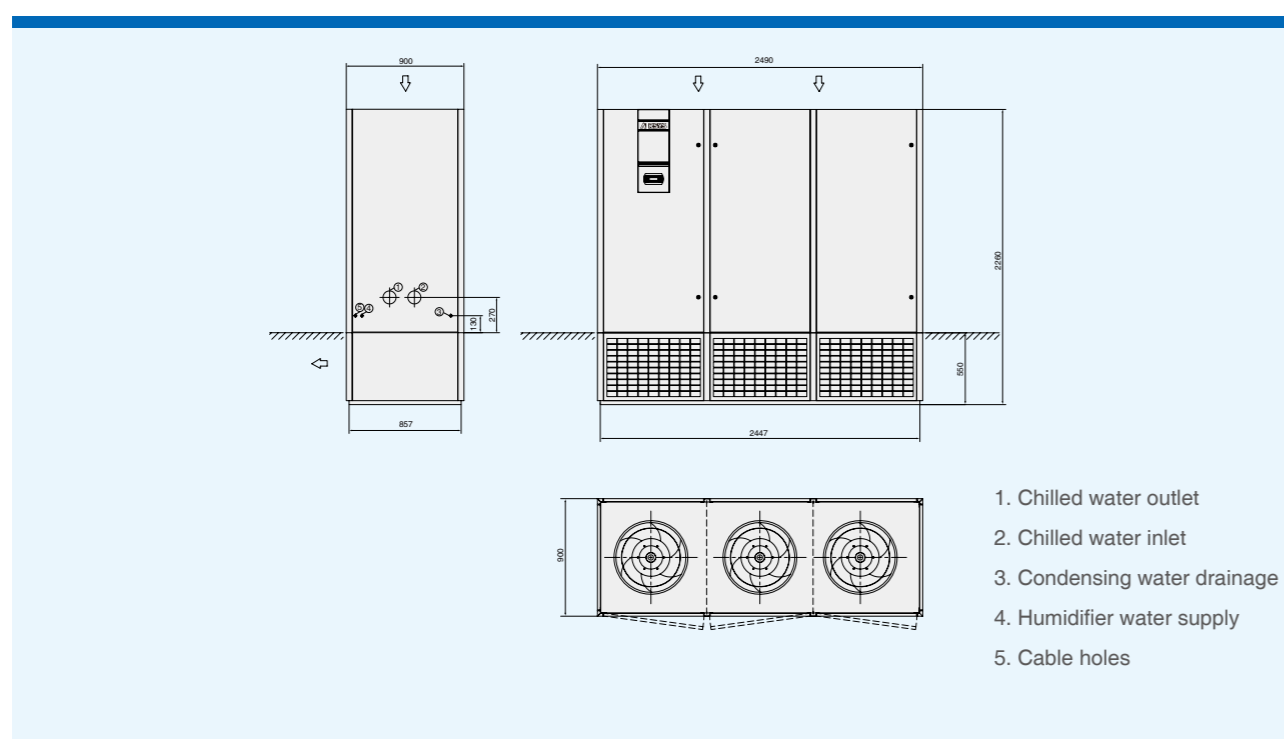

B4 Unit Cabinet Dimension Drawing for Under Flow Unit

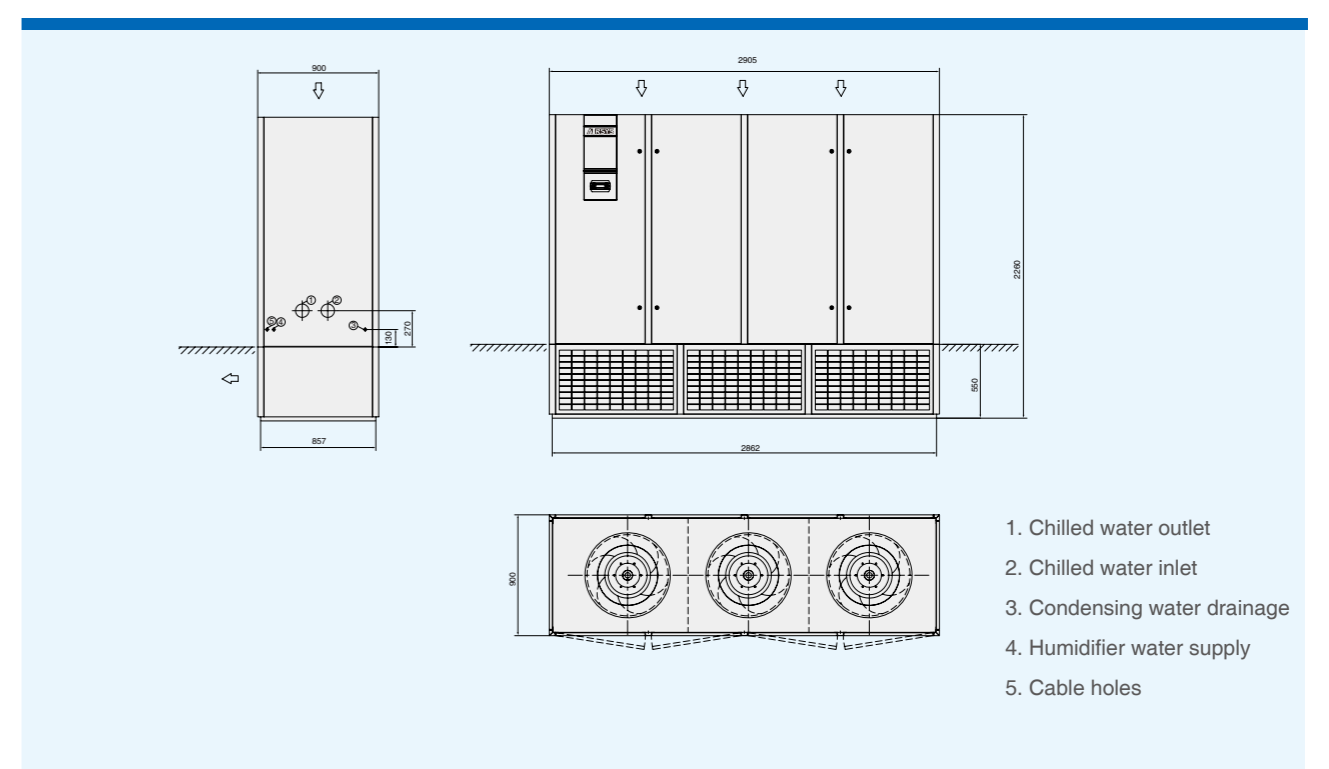

D1 Unit Cabinet Dimension Drawing

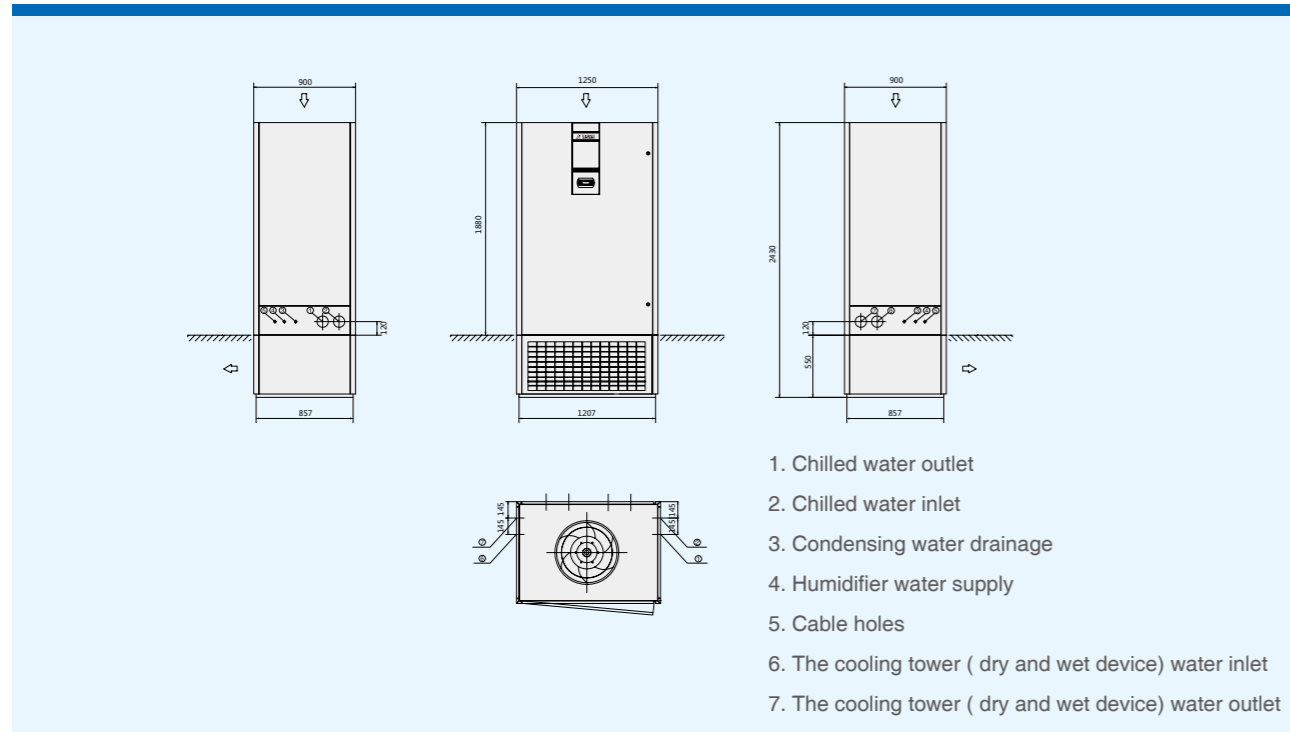

D3 Unit Cabinet Dimension Drawing

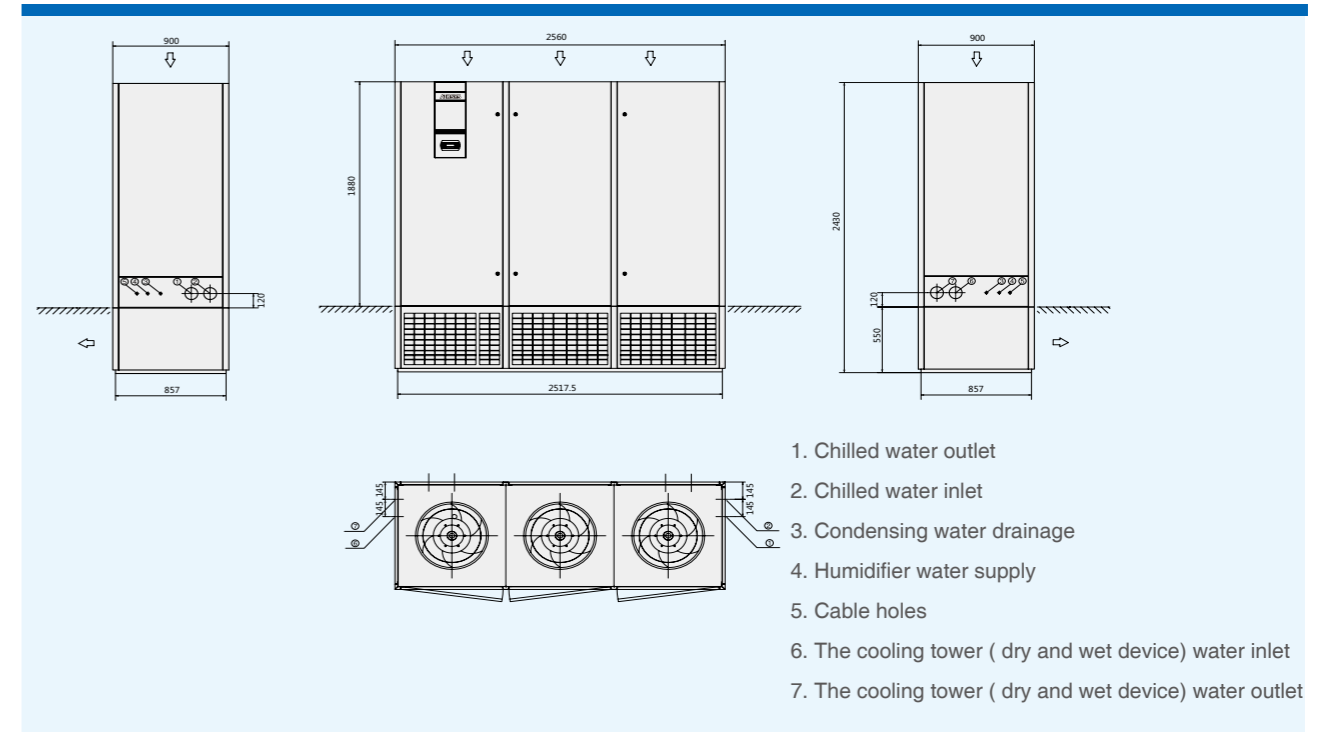

D2 Unit Cabinet Dimension Drawing

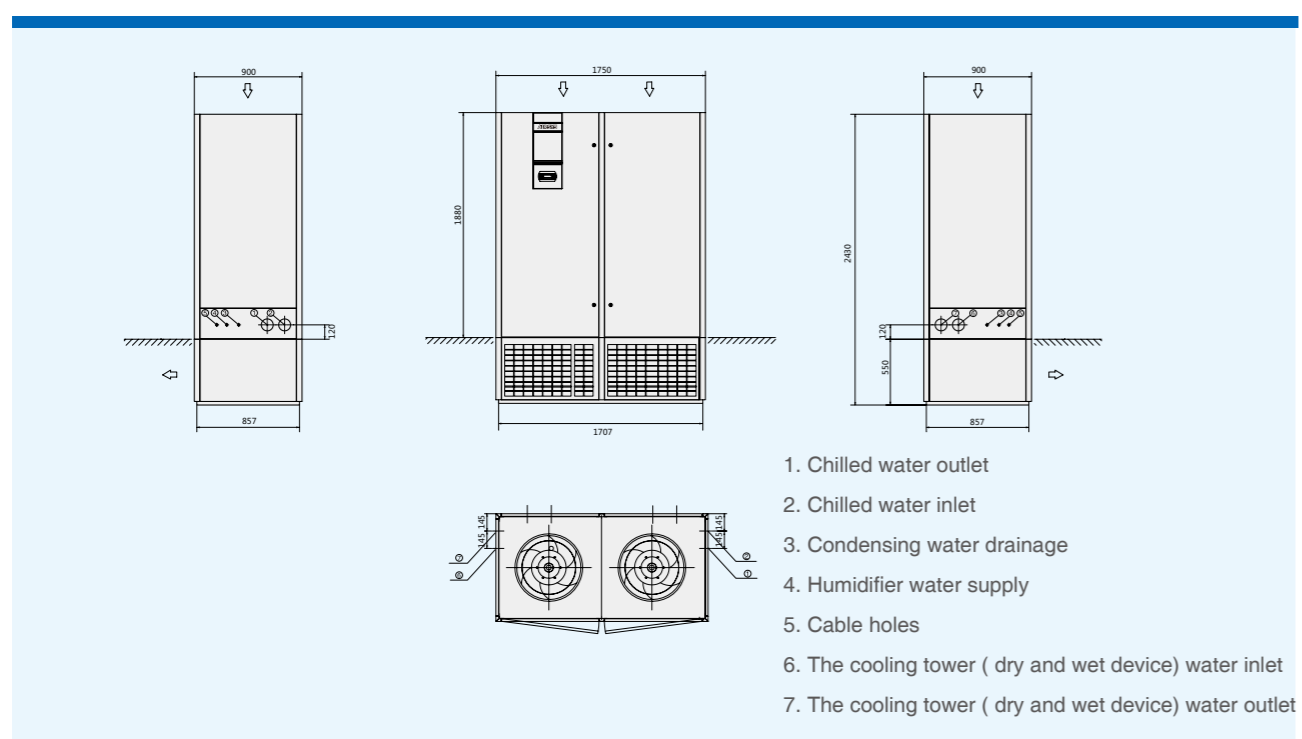



AIRSYS



AIRSYS

Expert In ICT Cooling

AIRSYS is a cooling product and solution provider for ICT (Information & Communication Technology) industry.

The products include:

- Air conditioner and Chiller for IT room and large data center
- Intelligent Control system (BAS) for IT room and data center
- Air conditioning equipments for telecom shelters
- Intelligent control system for shelter cooling.
- Air conditioner and heat exchanger for telecom cabinets.

The solution include:

- Cooling system design
- System integration
- Installation and Commissioning
- Operation and Maintenance

AIRSYS is also a global leader in providing cooling solution for Medical Imaging System.

Airsys Refrigeration Engineering Technology (Beijing) Co., Ltd.

Add: 10th floor, Hongkun Shengtong building, 19, Ping Guo Yuan Xi Xiao Jie, Shijingshan, Beijing, China 100043
Tel: +86(0)10 68656161

Gu'an Airsys Environment Technology Company Ltd.

Add: 25, Dongfang Street, Gu'an Industry Park, Langfang City, Hebei Province, China
Tel: +86(0)10 68656161

Shanghai Airserve HVAC System Service Co., Ltd.

Add: #7-2, No.658, Daduhe Rd., Putuo District, Shanghai, China, 200333
Tel: +86(0)21 62452626 Fax: +86 (0)21 62459622

AIRSYS Australia Sales Office

Add: PO BOX 1088, Flagstaff Hill, SA, 5159, Australia
Tel: +61 479151080

AIRSYS BRASIL LTDA.

Add: Av. Moaci, 395 Conj 35/36 04083-000 – Planalto Paulista SAO PAULO – SP
Tel: +55 (11) 25976817 / +55 (11) 21585560

AIRSYS Deutschland GmbH

Add: Dahlweg 120, D-48153 Münster Germany
Tel: +49 (0) 1757535054

AIRSYS Klima Sanayi ve Ticaret A.Ş.

Add: Barbaros Mah. Evren Cad. Erzurumlular Sk. No:23 Ataşehir / Istanbul Turkey
Tel: +90(216) 4706280 Fax: +90(216) 4706290

AIRSYS North America, LLC

ICT Cooling:
Add: 915 De La Vina St. Santa Barbara, CA 93101, USA
Tel: +1 (805) 312 7563 Call Centre: +1 (855) 874 5380
Medical Cooling:
Add: 3127 Independence Dr Livermore, CA 94551, USA
Tel: +1 800 7131543

AIRSYS Singapore Pte. Ltd

Add: 12 Lorong Bakar Batu #06-01 Singapore (348745)
Tel: +65 62787188 Fax: +65 68416301

AIRSYS (UK) Ltd.

Add: 245 Europa Boulevard, Warrington, UK. WA5 7TN
Tel: +44 (0) 1925 377 272 Call Centre: +44(0)8456099950

www.air-sys.com

Product design and specification subject to change without prior notice.